

DIRECTORATE OF DISTANCE & CONTINUING EDUCATION
MANONMANIAM SUNDARANAR UNIVERSITY TIRUNELVELI-

627 012



M.A., Journalism and Mass Communication

Audio Production

Prepared by

Dr. Harikrishnan D.

Assistant Professor Dept. of Visual Media and
Communication School of Arts , Humanities and
Commerce Amrita Vishwa Vidyapeetham,

Kochi Campus– 682024

Course Coordinator: Dr. V. Sundararaman

Expert Committee:

Dr.V.Sundararaman

Assistant Professor and Head i/c, Department of Communication
Manonmaniam Sundaranar University, Tirunelveli

Dr.Ghana D Hans

Assistant Professor, Department of Communication
Manonmaniam Sundaranar University, Tirunelveli

Dr Harikrishnan D

Assistant Professor & HoD, Department of Visual Media and Communication,
Amrita Vishwa Vidyapeetham, Kochi Campus.

Dr. S. Dinesh Babu

Assistant Professor, Department of Visual Media and Communication,
Amrita Vishwa Vidyapeetham, Kochi Campus.

Dr. R.Anusuah

Assistant Professor, Department of Visual Communication,
Mother Teresa Women's University, Kodaikanal

Dr. J.Lourdu Vesna

Assistant Professor, Department of Visual Communication,
Mother Teresa Women's University, Kodaikanal

Dr. M.Jebakumar

Assistant Professor, Department of Visual Communication,
St.Xaviers College Palayamkottai, Tirunelveli.

PROGRAMME OUTCOMES (PO)

PO1: Demonstrate comprehensive knowledge of journalism and media systems.

PO2: Apply ethical principles and professional standards in media practice.

PO3: Analyze media content, communication processes and public discourse.

PO4: Utilize digital technologies and multimedia tools in journalism.

PO5: Create responsible and socially relevant communication content.

Course Outcomes – Audio Production

After completing this course, students will be able to:

CO1 Explain the fundamentals of sound, sound waves and listening skills in audio production.

CO2 Apply microphone techniques and understand different types of microphones.

CO3 Analyze studio equipment such as mixers and consoles used in audio production.

CO4 Understand digital audio technology including ADC, DAC and DAWs.

CO5 Evaluate audio recording, mixing and mastering techniques.

Syllabus

Audio Production

Course Specific Objective

This course informs the students to the basic principles of the sound production and also students will gain hands on experience on sound recording and mixing

Hours Per Week

Credits

Lecture	1	Tutorial	1	Practical	1	3
---------	---	----------	---	-----------	---	---

UNIT I: Introduction to Audio

Sound and sound wave propagation - Active Listening Skills - Audio Cables and Interconnection

Unit II: Microphone techniques

Selection and Placement of Microphone - Technical skills - Different types of microphones
Accessories for Aiding Microphone

Unit III: Studio Equipment

Consoles and its types - Technical skills - Audio Mixers and Audio Consoles - Digital Mixers

Unit IV: Digital Audio Technology

Fundamentals of Digital Audio Technology - ADC, DAC - Digital Audio Workstation

Unit V: Mixing and Mastering Techniques

Combining individual tracks - Recording and editing skills - Audio Recording Software - Audio recording and editing software

Course Specific Skills

Active Listening	Technical skills	Technical skills	Technical skills	Recording and editing skills
------------------	------------------	------------------	------------------	------------------------------

Contents

Syllabus	1
Unit 1: Introduction to Audio	5
Sound and Sound Wave Propagation	5
Understanding Sound Waves.....	5
Key Characteristics of Sound Waves.....	5
Diagram of Sound Wave Propagation:.....	6
Examples of Sound Wave Behaviour	6
Active Listening Skills.....	7
Techniques for Improving Listening Skills	7
Case Studies on Active Listening in Audio Production:	8
Audio Cables and Interconnection.....	8
Types of Audio Cables.....	8
Diagrams of Cable Connections.....	12
Practical Tips for Maintaining and Troubleshooting Cables.....	13
Learning Activities.....	13
Unit II: Microphone Techniques.....	15
Selection and Placement of Microphones	15
Guidelines for Selecting Microphones Based on Recording Needs	15
Tips for Optimal Microphone Placements.....	15
Technical Skills.....	16
Step-by-Step Guide for Setting Up and Using Microphones.....	16
Tips for Avoiding Common Handling Mistakes.....	17
Types of Microphones	18
Dynamic Microphones.....	18
Condenser Microphones	18
Ribbon Microphones.....	19
Comparison Chart	20
Accessories for Aiding Microphones	20
Pop Filters	20
Shock Mounts.....	21
Windshields.....	22
Learning Activities.....	23

Unit III: Studio Equipment	25
Consoles and Their Types.....	25
Analog Consoles (Analog Mixers).....	25
Digital Consoles (Digital Mixers).....	26
Comparison of Analog and Digital Consoles.....	27
Technical Skills.....	28
Operating Audio Mixers and Consoles.....	28
Tips for Optimal Sound Quality.....	29
Audio Mixers and Audio Consoles: Functions and Features.....	30
Input Channels.....	30
Auxiliary Sends.....	30
Master Fader.....	31
Advanced Features Found in Modern Mixers.....	31
Features and Functions: Comparison.....	31
More about Digital Mixers.....	32
Advantages of Digital Mixers.....	32
Usage in Professional Settings.....	32
Learning Activities.....	33
Reading.....	33
Practice.....	33
Exercise.....	33
Unit IV: Digital Audio Technology	35
Fundamentals of Digital Audio Technology.....	35
Key Concepts in Digital Audio Technology.....	35
Sampling.....	35
Bit Depth.....	36
Digital Audio Formats:.....	36
Lossless Formats.....	37
Lossy Formats.....	37
Choosing the Right Format.....	37
Sampling: Diagram.....	38
ADC and DAC.....	38
Analog-to-Digital Conversion (ADC).....	38

Digital-to-Analog Conversion (DAC).....	39
Applications in Audio Production	39
Digital Audio Workstation (DAW)	40
Popular DAWs.....	40
Using a DAW: Step-by-Step Guide	43
Learning Activities.....	44
Reading.....	44
Practice:.....	45
Exercise:.....	45
Unit V: Mixing and Mastering Techniques	46
Combining Individual Tracks	46
Techniques for Balancing and Blending Tracks.....	46
Recording and Editing Skills.....	47
Step-by-Step Guide on Recording and Editing Audio	47
<i>Tips for Professional-Quality Recordings</i>	48
Audio Recording Software	49
Overview of Popular Recording Software	49
Audio Recording and Editing Software - General Workflow	50
Recording.....	50
Editing	50
Mixing and Mastering.....	51

Unit 1: Introduction to Audio

Sound and Sound Wave Propagation

Understanding Sound Waves:

Sound is a dynamic form of energy that moves through a medium such as air, water, or solid materials in the form of mechanical waves. These waves originate from objects that vibrate, setting the surrounding particles of the medium into motion. The vibrations cause particles in the medium to alternately compress and expand, creating regions of compression and rarefaction that propagate outward as sound waves. This continuous chain reaction allows the sound to travel from its source to a receiver, such as the human ear or a recording device. The behaviour and characteristics of these sound waves—such as their frequency, which determines pitch; amplitude, which influences loudness; and wavelength, which is related to the wave's speed and frequency—are crucial concepts in understanding how sound operates. Mastery of these principles forms the foundation for various applications in audio production, enabling precise manipulation and recording of sound for artistic and technical purposes.

Key Characteristics of Sound Waves:

Frequency

Frequency refers to the number of cycles a sound wave completes in one second, measured in Hertz (Hz). It determines the **pitch** of the sound. High-frequency waves result in high-pitched sounds (e.g., a whistle), while low-frequency waves result in low-pitched sounds (e.g., a drumbeat).

Amplitude

Amplitude is the height of the wave, which determines the **loudness** or volume of the sound. Larger amplitudes correspond to louder sounds, while smaller amplitudes result in softer sounds.

Wavelength

Wavelength is the distance between two successive points in the wave (e.g., from peak to peak or trough to trough). Wavelength is inversely related to frequency: higher frequency waves have shorter wavelengths, and lower frequency waves have longer wavelengths.

Diagram of Sound Wave Propagation:

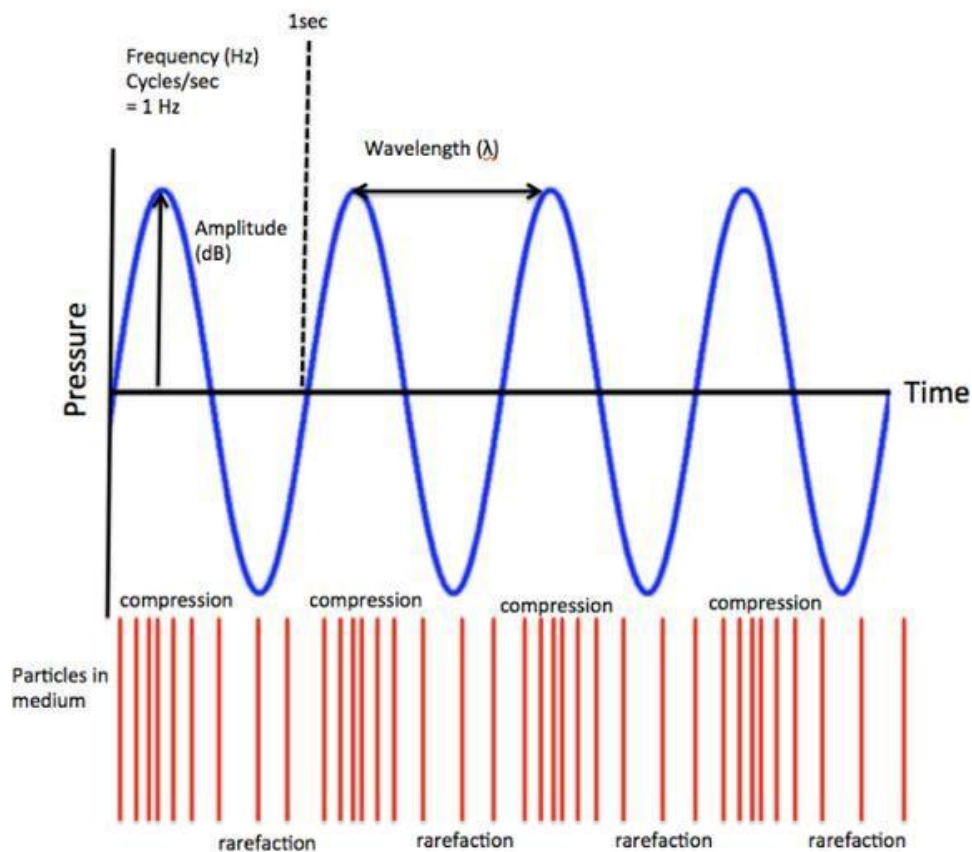

Diagram showing the sine wave representation of sound and its key characteristics: frequency, amplitude, and wavelength.

Examples of Sound Wave Behaviour:

In an Open Space (Free Field): In an open and unobstructed environment, sound waves radiate outward in all directions from their source in a uniform and spherical pattern. As these waves travel further from the source, their energy spreads over a larger area, causing the intensity to diminish gradually. This phenomenon, known as the inverse square law, states that the intensity of sound is inversely proportional to the square of the distance from the source. For example, the sound of a person shouting in a large field becomes softer as you move farther away because the energy disperses over a larger space.

In a Reflective Environment (e.g., Room with Walls): In enclosed spaces with reflective surfaces such as walls, ceilings, or floors, sound waves do not travel freely. Instead, they interact with the surfaces, bouncing back to create echoes and reverberations. Echoes are distinct repetitions of sound caused by the reflection of sound waves, while reverberations are the prolonged persistence of sound as waves continuously reflect and

overlap. These effects can either distort or enrich the sound, depending on the acoustics of the environment. For instance, a concert hall is carefully designed to enhance sound with controlled reverberation, creating a rich and immersive auditory experience. In contrast, a small, untreated room may produce excessive echoes or muffled sounds, making communication or recording less clear.

Through Different Mediums: The speed of sound depends on the properties of the medium through which it travels. Denser mediums like water or metal facilitate faster sound wave transmission compared to less dense mediums such as air. This occurs because particles in denser materials are more closely packed, allowing vibrations to transfer more efficiently. This principle is commonly observed in underwater communication systems, where sound travels approximately 4.3 times faster in water than in air. Similarly, tapping on one end of a metal rod allows the sound to reach the other end almost instantly due to the high transmission speed in the dense material. Understanding these differences is vital in fields such as acoustics, sonar technology, and industrial applications.

Active Listening Skills

Active listening is a crucial skill in audio production. It involves not just hearing but critically analysing and understanding the different elements of sound. Active listening in audio production is the focused, intentional listening to sounds, recognizing notes, and identifying specific elements within the audio. It involves not just hearing but understanding and interpreting the sound to make informed decisions during production.

This includes:

1. **Identifying different sound sources:** Recognizing instruments, voices, and other sound elements.
2. **Understanding sound quality:** Evaluating clarity, balance, and dynamics.
3. **Critical listening:** Focusing on specific aspects of the audio to identify areas for improvement.

Techniques for Improving Listening Skills:

Isolate Sounds: One of the fundamental techniques to sharpen listening skills is learning to isolate individual elements in an audio track. This involves consciously focusing on distinct components, such as separating the main vocals from the background music or identifying specific instruments like the bass guitar, drums, or strings in a song. By mentally tuning into one element at a time, you can gain a deeper understanding of how each part contributes to the overall composition.

Practicing this technique regularly trains your ears to identify subtle nuances in audio, which is an essential skill for audio editing, mixing, and sound design.

Focus on Frequency Range: Developing an awareness of different frequency ranges helps you understand the tonal balance of an audio mix. Start by identifying the bass, which lies in the lower frequencies and provides depth and rhythm to a track. Next, pay attention to the midrange, where most vocals and primary instruments reside, forming the core of the mix. Finally, focus on the treble or high frequencies, which add sparkle and clarity to the sound. Listening with attention to these ranges enables you to discern how each frequency band interacts with others, helping you make precise adjustments during audio production to achieve a balanced and dynamic mix.

Use Reference Tracks: Listening to professionally mixed and mastered tracks, often referred to as reference tracks, is a highly effective way to improve your listening skills. By comparing your own audio work to high-quality tracks, you can identify differences in clarity, balance, panning, and overall texture. For instance, a reference track can help you determine whether your bass levels are too overpowering or if your vocals are lacking presence. Analyzing these differences trains your ear to recognize what constitutes a well-crafted mix, allowing you to apply similar techniques and standards to your own projects.

Case Studies on Active Listening in Audio Production:

Case Study 1: Mixing in Music Production.

A music producer's ability to differentiate between frequencies can greatly affect how instruments blend in a track. Active listening helps a producer identify if the bass is overpowering the vocals or if the treble frequencies are too harsh.

Case Study 2: Sound Design for Film.

In film sound design, active listening is key to creating a realistic auditory environment. By understanding how sound behaves in different spaces (e.g., a hallway, an open field, or a crowded street), a sound designer can select or create sounds that enhance the visual storytelling.

Audio Cables and Interconnection

Types of Audio Cables:

Audio cables are essential for connecting various audio equipment. Understanding the types of cables and their uses ensures proper signal flow and minimizes noise and

interference, and it is essential for setting up and troubleshooting any audio production system.

The most common types of audio cables are:

XLR Cable

XLR cables are used for balanced audio signals. They are commonly used for microphones, and their three pins (positive, negative, and ground) help eliminate noise and interference during signal transmission. This is considered as the most reliable and clean connectors for professional audio devices. Balanced audio allows to stretch cables across long distances without significant added noise. This happens through the clever use of 2 different signals being transported inside the cable, one in-phase and one out-of-phase, so that external interferences can be nulled.

In addition to the audio signal, they can also carry a low voltage (48v known as phantom power) to power condenser microphones and DI boxes. XLR cables are also used for lighting, amplified signals and power transportation and they can have up to 7 pins.



Usage: Microphones, professional audio equipment.

TRS (Tip-Ring-Sleeve) Cable

TRS cables, also called 1/4-inch stereo cables, carry balanced audio signals. They are often used for headphones or line-level connections, with three sections: tip, ring, and sleeve. The TRS jack plug (Tip-Ring-Sleeve) is a versatile connector commonly found on audio mixers, outboard gear, and professional as well as consumer headphones. Known for its reliability and ability to transmit stereo audio or balanced signals, the TRS jack has become a standard in the audio industry. The larger 6.35mm TRS jack is typically used in professional setups, including studio headphones and audio equipment, while its smaller counterpart, the 3.5mm version, has gained widespread use in consumer electronics.

The 3.5mm TRS jack, also referred to as the stereo mini jack, rose to prominence during the 1980s with the advent of portable audio devices like the iconic Sony Walkman cassette players. Its compact size made it ideal for portable applications, offering convenience and compatibility. Decades later, it remains a ubiquitous choice for most portable audio devices, including smartphones, tablets, laptops, and MP3 players. Despite the growing adoption of wireless technologies, the stereo mini jack continues to be a crucial component in both legacy and modern audio systems due to its simplicity and widespread support.



Usage: Stereo headphones, line-level devices, mixers.

RCA Cable

RCA cables are a widely recognized standard for carrying unbalanced audio signals and have been a mainstay in consumer-level audio equipment for decades. Easily identifiable by their distinctive color-coding—red for the right audio channel and white (or sometimes black) for the left—they simplify the process of connecting stereo devices. These connectors, named after the Radio Corporation of America, were first introduced in the 1940s and quickly became a consumer standard for audio and video applications.

Typically used in pairs, RCA cables are designed to transmit analog unbalanced signals at a -10 dBV line level, making them ideal for consumer-grade equipment like Hi-Fi systems and DJ setups. Additionally, RCA connectors have historically been associated with turntables (phono), where they are used to connect record players to amplifiers with proper preamps for optimal audio quality. Their role in video transmission was also prominent for decades, particularly for composite and component video signals.

However, the advent of digital video standards, particularly HDMI, has rendered RCA connectors largely obsolete for video applications. HDMI's ability to transmit high-definition video and multi-channel audio in a single cable has led to a significant decline in the use of RCA connectors for modern video setups. Despite this, RCA cables remain

relevant in audio applications, particularly in legacy systems, home audio setups, and DJ equipment, where their simplicity and widespread compatibility continue to make them a practical choice.

The enduring utility of RCA cables in specific contexts underscores their historical importance and the evolving landscape of audio and video connectivity.



Usage: Home audio systems, consumer-grade equipment.

TS (Tip-Sleeve) Cable

TS cables (Tip and Sleeve) are a foundational component in audio technology, widely used for unbalanced mono connections. Characterized by their straightforward design, these cables are ideal for transmitting analog audio signals from devices with unbalanced outputs. The 1/4-inch (6.3mm) TS jack plug, the most common variant, is a staple in the music and audio industry, known for its simplicity, sturdiness, and durability.

Originally developed for telephone switchboards in the early 20th century, the TS jack quickly found applications in audio due to its robust build and reliable performance. It carries a mono signal, with the tip transmitting the audio signal and the sleeve acting as the ground. While its unbalanced nature makes it susceptible to noise over long distances, it remains the standard for many applications where cable runs are short and interference is minimal.

In the world of music, TS cables are indispensable. They are the go-to choice for connecting electric bass and guitars, synthesizers, and other audio equipment with unbalanced outputs. Their rugged design ensures they can withstand the demands of live performances and studio environments, contributing to their extraordinary longevity as an industry standard.

The enduring popularity of TS cables highlights their versatility and reliability. While newer technologies have emerged, TS cables continue to play a crucial role in connecting musical instruments and audio gear, proving that simplicity and robustness can stand the test of time.



Usage: Electric guitars, keyboards.

Diagrams of Cable Connections:



Different types of cables and their respective connectors

Practical Tips for Maintaining and Troubleshooting Cables:

Cable Maintenance:

- Regularly check cables for wear and tear, as they can become damaged over time. Always coil cables properly to avoid internal damage.
- Keep cables away from sharp edges or areas where they can be bent or twisted frequently.

Troubleshooting Tips:

- **No Sound Output:** Check if the cable is properly plugged in, test with another device, or try a different cable.
 - **Static Noise:** If there's interference or static, ensure that all cables are securely connected and are not subject to electromagnetic interference (EMI) from other equipment.
 - **Signal Loss:** For long cable runs, use high-quality cables and connectors to reduce signal loss.
-

Learning Activities

(By regularly practicing these exercises, you can hone your auditory skills, enabling you to identify and manipulate sound and frequencies with precision in audio production.)

1. Frequency Sweep Exercise: This exercise focuses on recognizing and distinguishing frequency ranges, a critical skill for audio production.

- Steps:
 1. Use an audio frequency generator or a pre-recorded frequency sweep track that gradually increases in pitch from low to high frequencies.
 2. Play the sweep through high-quality headphones or monitors to ensure clarity.
 3. As the sound sweeps through the spectrum, identify key frequency ranges:
 - Low Frequencies (Bass): Typically, between 20 Hz and 250 Hz, where deep, rumbling tones reside.
 - Midrange Frequencies: From 250 Hz to 4 kHz, where vocals and most instruments are prominent.
 - High Frequencies (Treble): Above 4 kHz, contributing to clarity and sparkle in the sound.
- Goal: Develop an ear for recognizing the tonal characteristics and contributions of different frequency ranges.
- Variation: Reverse the process by sweeping from high to low frequencies to reinforce identification skills.

2. Sound Isolation Exercise: This exercise trains you to focus on individual sounds within a complex mix and recognize their unique frequency characteristics.

- **Steps:**
 1. Select recordings of music from diverse genres, (such as classical, jazz, and rock.)
 2. Listen to the track and focus on one instrument or sound at a time (e.g., bass guitar, snare drum, violin, sitar or lead vocal).
 3. Try to identify the approximate frequency range of each isolated sound:
 - Bass instruments generally occupy the lower frequencies (20 Hz to 300 Hz).
 - Vocals and melodic instruments dominate the midrange (300 Hz to 3 kHz).
 - Cymbals and hi-hats contribute to the upper frequencies (above 3 kHz).
 4. Note the tonal qualities and dynamics of the sound within the mix.
- **Goal:** Improve your ability to focus on individual sound elements, making it easier to work on balancing and equalizing them during mixing.
- **Advanced Variation:** Use an equalizer plugin to solo specific frequency ranges while listening to the track. This will provide a clearer understanding of how different frequencies shape the overall sound.

Check Your Progress

Short Answer Questions

Question	CO	PO	K
Define sound and sound wave propagation.	CO1	PO1	K1
Explain the characteristics of sound waves.	CO1	PO3	K2
What is active listening in audio production?	CO1	PO3	K1
Define frequency and amplitude in sound waves.	CO1	PO3	K1
Explain the types of audio cables used in sound systems.	CO1	PO4	K2

Essay Questions

Question	CO	PO	K
Discuss the concept of sound wave propagation.	CO1	PO1	K3
Analyze the characteristics of sound waves in audio production.	CO1	PO3	K4
Explain the importance of active listening skills in sound production.	CO1	PO3	K3
Examine different types of audio cables and their applications.	CO1	PO4	K4
Evaluate the role of sound fundamentals in audio production.	CO1	PO5	K5

Unit II: Microphone Techniques

Selection and Placement of Microphones

Microphone selection and placement are critical in ensuring high-quality audio recordings because they directly influence the clarity, tone, and overall sound of the captured audio. The type of microphone chosen—whether dynamic, condenser, or ribbon—plays a significant role in determining the microphone’s sensitivity, frequency response, and suitability for different recording environments. For instance, condenser microphones are often preferred for studio recordings due to their ability to capture a wider frequency range and finer details, while dynamic microphones are more robust and better suited for high-pressure sound environments, such as live performances. In addition to selecting the right microphone, proper placement is equally important. The distance between the microphone and the sound source, the angle of placement, and the positioning relative to potential reflective surfaces can greatly affect how the sound is captured. Placing a microphone too close to a sound source might result in distortion, while positioning it too far could lead to a loss of clarity. Understanding the acoustic properties of the recording space and adjusting accordingly ensures that the microphone captures the most accurate and balanced representation of the sound. Both these factors—selection and placement—are foundational in producing recordings that are both technically proficient and sonically pleasing.

Guidelines for Selecting Microphones Based on Recording Needs

1. **Type of Sound Source:** Understand the sound source—whether it's vocals, musical instruments, or ambient sound.
 - For vocals, a condenser microphone is often preferred due to its sensitivity and frequency range.
 - For loud instruments like drums, a dynamic microphone is suitable.
2. **Recording Environment:** Consider the acoustics of the recording space.
 - For controlled studio environments, condenser microphones excel.
 - For outdoor or noisy areas, dynamic microphones are more practical.
3. **Purpose of Recording:**
 - For broadcasting or podcasts, a large-diaphragm condenser microphone is ideal.
 - For film production, shotgun microphones are commonly used.

Tips for Optimal Microphone Placements

Vocals: For recording vocals, positioning the microphone correctly is essential to capture a clean and clear sound. Ideally, place the microphone 6-12 inches away from the vocalist's mouth, with the microphone slightly angled downward or to the side to avoid capturing plosives (the harsh 'P' and 'B' sounds that can cause distortion). The distance helps maintain an even balance between the voice and the natural room acoustics, avoiding excessive proximity effects (which can make the voice sound boomy

or overly bass-heavy). Additionally, using a pop filter in front of the microphone can help mitigate plosives and ensure a smoother recording.

Acoustic Guitar: When setting a mic for an acoustic guitar, the 12th fret is often the ideal starting point. Place the microphone around 6-12 inches from the fretboard, pointing towards the sound hole. This placement captures the balance of the guitar's tonal range, offering a clear representation of both the bright, higher frequencies from the strings and the deeper, warmer tones from the body. It is important to avoid pointing the mic directly at the sound hole, as this can cause excessive boominess and muddiness. Experimenting with the angle of the microphone can also reveal different tonal qualities, allowing for a more tailored sound.

Drums: Drums require a multi-microphone setup due to their diverse sounds and the need to capture each element distinctly. For individual drums, place microphones close to each drum or cymbal—snare, kick, and toms—to capture their specific characteristics. For the kick drum, a microphone placed inside or just outside the drum's resonant head will pick up the punch and low-end frequencies. For the snare, position the mic a few inches above, aiming at the centre of the drum, ensuring it picks up the sharp attack and snap. When mic'ing toms, angle the microphone towards the drum's centre, while being mindful not to place it too close, which could cause distortion.

These general tips serve as a starting point, and subtle adjustments based on the specific space and sound desired can further enhance the quality of the recording.

Technical Skills

Step-by-Step Guide for Setting Up and Using Microphones

- **Assemble the Microphone:** Start by attaching the microphone to a sturdy stand. If available, use a **shock mount** rather than a standard clip. A shock mount isolates the microphone from vibrations that can cause unwanted noise or distortion. Ensure that the microphone is securely attached and adjust the height and angle to suit the sound source.
- **Connect to Equipment:** Next, connect the microphone to your audio equipment using an **XLR cable**. XLR cables are the standard for professional-grade microphones because they carry balanced signals, reducing the chance of noise or interference during transmission. Ensure that the cable is properly plugged into the microphone and the audio interface or mixer. If you're using a condenser microphone, ensure that the microphone is receiving **phantom power** (typically +48V), which is required for operation. For dynamic microphones, phantom power is not required.
- **Adjust Gain Levels:** Once the microphone is connected, it's important to adjust the **gain levels** on your audio interface or mixer. Gain determines how

much signal the microphone will send to the equipment, and it needs to be set appropriately. Too little gain will result in a weak, inaudible signal, while too much gain can cause **clipping** and distortion. Start with the gain knob at a low setting and gradually increase it while monitoring the signal levels. Aim for a healthy signal without distortion—peaks should not reach the red zone on your level meter. If you notice distortion, reduce the gain slightly and check the microphone placement.

- **Test the Setup:** Before starting your recording session, always perform a sound check. This step is essential to identify any potential issues that might affect the quality of your recording. Speak or play the instrument into the microphone, and carefully listen for any issues like **pops**, **hums**, or **feedback**. If you hear distortion or feedback, try repositioning the microphone or adjusting the gain levels again. Ensure the room environment is suitable as well—check for any noises that might interfere with the recording. If using a condenser microphone, be mindful of any reverberation or reflective surfaces that might alter the sound.

By following these steps, you ensure that the microphone setup is optimized for the recording session, allowing you to achieve the highest sound quality possible.

Tips for Avoiding Common Handling Mistakes

- **Avoid Touching or Moving the Microphone During Recording:** One of the most common mistakes in microphone handling is inadvertently touching or moving the microphone while recording. This can introduce **handling noise**—unwanted sounds caused by vibrations and physical movement of the microphone, which may be picked up by the mic itself. To avoid this, make sure the microphone is securely positioned on a **shock mount** or stand before you start recording, and refrain from adjusting it once the session begins. If you need to reposition the microphone during the recording, do so carefully and silently. This simple practice ensures that no unexpected noises or shifts in sound quality occur during the recording process.
- **Use a Pop Filter to Reduce Plosives:** Another key handling mistake is neglecting to use a **pop filter**. Pop filters are essential tools for reducing **plosives**—the loud, sharp bursts of air produced when pronouncing consonants like "P" and "B." These sudden bursts of air can cause distortion or clipping in the microphone, particularly when the mic is placed too close to the mouth. By positioning a pop filter a few inches from the microphone, you allow the filter to diffuse the air pressure, resulting in cleaner and more balanced recordings. This is particularly crucial for vocal recordings where clarity and smoothness are vital.
- **Ensure Cables Are Securely Connected:** Loose or improperly connected cables are a frequent source of interruptions and poor audio quality. Always check that the **XLR cables** are securely plugged into both the microphone and the recording device or mixer. A loose connection can lead to **signal loss**, static noise, or even

complete dropouts during a recording session. Additionally, avoid placing cables in positions where they might be tugged or accidentally unplugged. If you're using long cables, coil them properly to prevent them from becoming tangled or damaged, and make sure they're positioned out of the way to avoid tripping or pulling during a session. A secure, organized setup ensures a stable audio signal and a smoother recording process.

By being mindful of these common handling mistakes, you can improve the quality and professionalism of your recordings, ensuring cleaner, more consistent results.

Types of Microphones

Dynamic Microphones

- **Description:** Dynamic microphones are known for their durability and ability to withstand high sound pressure levels (SPL). These microphones operate through an electromagnetic principle, where a diaphragm moves within a magnetic field, generating an electrical signal that corresponds to sound. Due to their robust design, dynamic microphones are ideal for handling loud sound sources without distortion.
- **Applications:** Dynamic microphones are commonly used in **live performances**, such as concerts, where high SPL is typical. They are also frequently used for **recording drums**, particularly for miking snare drums and kick drums, and for **amplifiers** (like guitar amps), where a durable mic is necessary to handle the loud, distorted sound.

Pros:

- Highly rugged and durable, making them ideal for touring and live sound applications.
- Generally, more affordable than other types of microphones.
- Capable of handling high SPL without distortion.

Cons:

- Less sensitive than other microphones, meaning they may not capture subtle details, such as the nuances of vocals or acoustic instruments.
- The frequency response tends to be narrower, resulting in less fidelity for certain applications

Condenser Microphones

- **Description:** Condenser microphones are highly sensitive and offer exceptional clarity and detail, making them a favourite for professional **studio recordings**. They work through a capacitive diaphragm that requires **external power**, often provided by **phantom power** (typically 48V), to charge the diaphragm and allow it to pick up sound. This design enables them to capture a wide frequency range and subtle sounds accurately.

- **Applications:** Condenser microphones are the go-to choice for recording **vocals** and **acoustic instruments** in a controlled studio environment. They are often used in **voice-over work**, podcasting, and **studio vocals** due to their ability to capture fine details and high fidelity.

Pros:

- Excellent **sensitivity** and **high fidelity**, making them ideal for capturing rich, detailed audio.
- Broader frequency response, making them suitable for a wide variety of recording scenarios.

Cons:

- More **fragile** than dynamic microphones, making them less suited for handling high SPLs or rough handling.
- Require **phantom power**, adding an additional setup requirement.
- Typically, more **expensive** than dynamic microphones, especially higher-end models.

Ribbon Microphones

- **Description:** Ribbon microphones have a distinctive, vintage design and operate by using a thin metal ribbon suspended in a magnetic field. When sound waves strike the ribbon, they cause it to vibrate, generating an electrical signal. This type of microphone is celebrated for its **natural warmth** and smooth response.
- **Applications:** Ribbon microphones are often used for capturing **warm tones** in studio environments, particularly for **vocals**, **strings**, and other **acoustic instruments**. They are also used in some applications in broadcasting and film audio due to their rich, vintage sound quality.

Pros

- Exceptional sound quality, known for its smooth and natural tonality, especially in the midrange.
- Provides a vintage sound that is highly sought after in certain genres of music and recording contexts.

Cons:

- Extremely **delicate**, as the ribbon is fragile and can be damaged easily, particularly by high SPLs (Maximum sound pressure level- highest sound level a microphone can handle before distorting).
- **Expensive** compared to dynamic and condenser microphones.
- **Low output level:** Ribbon microphones tend to produce a lower output, which may require a high-gain preamp.

Comparison Chart

Type	Sensitivity	Best Use	Durability	Price Range
Dynamic	Moderate	Live sound	High	Low
Condenser	High	Studio recording	Medium	Moderate
Ribbon	Very high	Vintage recording	Low	High

Accessories for Aiding Microphones

Pop Filters

Purpose: Pop filters are an essential accessory used to reduce or eliminate **plosives**, which are the unwanted bursts of air that occur when speaking certain consonants like "P" and "B". These plosives can cause a sharp distortion or distortion in the sound signal, often resulting in an unpleasant and jarring noise that disrupts the recording. Pop filters help maintain a clean and smooth recording by diffusing these bursts of air before they reach the microphone.

Placement: Typically, a pop filter is positioned approximately **2-3 inches** away from the microphone. This distance allows the filter to effectively diffuse the air pressure while preventing it from interfering with the sound capture. It's important not to place the pop filter too close to the microphone, as it could interfere with the sound source or cause a muffled recording.



Microphone fitted with Pop Filter.

Benefits:

- Reduces plosives, which are particularly problematic for vocal recordings.
- Helps in achieving a clearer and more professional vocal sound by eliminating unwanted noises caused by breath blasts.

- Preserves the integrity of the recording, especially for **podcasts**, **voice-overs**, and **singers**, where clarity is paramount.

Shock Mounts

Purpose: A shock mount is designed to isolate the microphone from mechanical vibrations and **handling noise** that might be transmitted through the microphone stand or surrounding surfaces. Without a shock mount, any accidental bumps, handling of the stand, or even vibrations from nearby equipment can affect the audio quality, resulting in unwanted thuds or hums in the recording. Shock mounts are especially important in professional studio settings where consistent sound clarity is critical.

How They Work: Shock mounts use flexible materials (like rubber or elastic bands) to suspend the microphone in a way that isolates it from physical movements. These materials prevent vibrations from being transmitted from the stand into the microphone capsule. This makes shock mounts particularly useful in situations where the microphone may be touched or moved slightly during a recording, such as during live performances or instrument recording sessions.



Shock mount

Benefits:

- **Minimizes vibrations:** Prevents handling noises and mechanical vibrations from affecting the microphone's performance.
- **Ensures clean recordings:** Helps achieve high-quality, distortion-free recordings by reducing unwanted noise sources.
- **Preserves microphone integrity:** By minimizing the strain and wear caused by vibrations, shock mounts help to extend the life of the microphone.

Windshields

Purpose: Windshields, also known as **windscreens**, are primarily used to reduce **wind noise** when recording outdoors. Wind blowing directly onto a microphone can cause disruptive low-frequency rumble or high-pitched gusts that distort the audio, making it unusable. A windshield acts as a barrier, helping to diffuse the wind and reduce the intensity of the noise that the microphone captures.

Types: Windshields come in various shapes and sizes, and they can be made from different materials depending on the environment and type of recording. The most common types include:



Foam Windshield and Furry windshield.

- **Foam windshields:** These are lightweight and fit snugly over the microphone, offering basic protection from light wind.
- **Furry windshields (also known as dead cats):** These are typically used for more extreme outdoor conditions, such as when recording in high winds. The furry material provides an additional layer of protection against wind interference, effectively reducing low-frequency wind noise.

Benefits:

- **Reduces wind noise:** Ideal for outdoor recordings, especially when recording in areas with significant wind exposure, like outdoor interviews or field recordings.

- **Improves audio clarity:** By mitigating wind noise, windshields ensure that the desired sound source, whether it be a voice or an instrument, is captured clearly without distortion.
 - **Prevents damage:** Windshields help protect the microphone's delicate diaphragm from direct exposure to harsh elements like wind, dust, or moisture, preserving its longevity and performance.
-

Learning Activities

(These learning activities are designed to build both theoretical knowledge and practical skills. By combining reading, hands-on practice, and critical analysis of recordings, students will gain a deeper understanding of microphone techniques, allowing them to make informed decisions about equipment and setups in different recording environments.)

- **Reading - Study Guides on Microphone Types and Accessories:** The first step in understanding microphone techniques is to engage with informative resources that cover the theory behind microphone types and their accessories. In this reading activity, students will explore comprehensive guides, textbooks, and articles that discuss various types of microphones, their construction, and their use cases. The material will cover dynamic, condenser, and ribbon microphones, providing in-depth explanations of how they differ in sensitivity, durability, and performance across various recording scenarios. In addition to microphone types, the guides will include information on essential accessories such as pop filters, shock mounts, and windshields. These accessories play a crucial role in ensuring clean, professional-quality recordings by addressing issues like plosives, vibrations, and environmental noise. The goal of this activity is to help students develop a foundational understanding of the equipment they'll be working with and its practical applications in audio production.
- **Practice - Set Up Microphones in a Studio and Outdoor Environment:** This hands-on activity allows students to put their theoretical knowledge into practice by setting up microphones in different environments. In the controlled setting of a studio, students will learn how to properly mount microphones, adjust gain levels, and position microphones based on the specific needs of the audio source, whether it's vocals, instruments, or voice-over work. The students will explore optimal placement techniques, ensuring the microphone captures sound clearly and with minimal interference from external factors. In contrast, the outdoor setting will challenge students to handle more complex scenarios such as wind noise, unpredictable acoustics, and environmental factors that can impact sound quality. Here, students will learn how to use appropriate accessories like pop filters, shock mounts, and windshields to

address issues specific to outdoor recording. By setting up microphones in both environments, students will develop the ability to adapt to various recording conditions, making decisions based on the unique acoustics of each space.

- **Exercise - Record Audio with Different Placements and Analyse the Output Quality:** In this exercise, students will experiment with various microphone placements and analyse the resulting audio quality. They will set up microphones in different configurations for different audio sources, such as vocals, instruments, and group recordings. The students will test microphone distances, angles, and placements (e.g., near the sound source, at a distance, or angled) to see how these adjustments affect the clarity, balance, and overall quality of the recorded sound. After recording, students will listen critically to the audio to assess whether the microphone placement and setup provided the desired results. They will evaluate the recordings for any distortion, clarity issues, or unwanted noises, such as plosives or handling noise, which might have affected the quality of the output. This activity will help students learn how to fine-tune their microphone placement to achieve optimal sound and develop critical listening skills. Additionally, students will be encouraged to make necessary adjustments in real-time, enhancing their ability to troubleshoot and adapt to varying recording situations.

Check Your Progress

Short Answer Questions

Question	CO	PO	K
Define microphone techniques.	CO2	PO1	K1
What are dynamic microphones?	CO2	PO4	K1
Explain condenser microphones.	CO2	PO4	K2
Define ribbon microphones.	CO2	PO4	K1
Explain the role of pop filters and shock mounts.	CO2	PO4	K2

Essay Questions

Question	CO	PO	K
Discuss the principles of microphone selection and placement.	CO2	PO4	K3
Analyze different types of microphones used in audio production.	CO2	PO4	K4
Explain microphone accessories and their functions.	CO2	PO4	K3
Examine microphone placement techniques for different sound sources.	CO2	PO3	K4
Evaluate the importance of microphone techniques in professional recording.	CO2	PO5	K5

Unit III: Studio Equipment

(This unit equips students with in-depth knowledge of studio equipment, enabling them to operate mixers and consoles confidently in various professional audio production settings.)

Consoles and Their Types

Audio consoles, often referred to as mixers or mixing desks, are essential pieces of equipment in both studio and live audio production. These consoles allow audio engineers to combine, route, adjust, and balance multiple audio signals to create a cohesive and high-quality sound output. Depending on the type of audio production and desired sound characteristics, audio consoles can vary significantly in design and functionality. There are two primary types of audio consoles: **Analog Consoles** and **Digital Consoles**. Each has its own set of features and applications that cater to different production needs.

Analog Consoles (Analog Mixers)

Analog consoles are the traditional type of audio mixers that process audio signals using physical, analog circuitry. These consoles utilize electronic components like resistors, capacitors, and transistors to manipulate audio signals in their pure, analog form. They are known for their distinctive sound characteristics, often referred to as "warm" and "natural," which is attributed to the analog signal path. Analog mixers are considered the more traditional option compared to their digital counterparts due to their long-standing presence in audio production. They are typically more affordable, particularly at entry-level, and can be easily managed by even novice users for a wide range of live sound reinforcement applications. These mixers feature straightforward signal routing, with inputs hard-wired to specific channel strips. Channel processing is localized between the input gain and the output fader, enabling quick adjustments to EQs or sends by simply manipulating the corresponding control. Experienced sound engineers appreciate the tactile feedback provided by the distinct physical controls, which allow for quick assessment and resolution of signal flow issues. Additionally, the design consistency across analog mixers ensures minimal learning curves when transitioning between different models.

Features:

- **Warm and Natural Sound:** Analog consoles are known for producing a rich and organic sound, often preferred for their smooth tonal qualities and harmonic distortion, which adds a certain character to the audio that digital systems may not replicate in the same way.
- **Physical Knobs and Sliders:** Analog consoles typically feature tactile controls, such as knobs, faders, and sliders, which allow engineers to manually adjust levels, EQ, and other parameters. This hands-on control is often seen as more intuitive and direct compared to digital systems.

Applications:

- Analog consoles are favoured in studios where traditional, hands-on operation is valued. Engineers who prefer to work with physical controls often opt for analog mixers due to their simple, straightforward interface and the unique sound qualities they offer. These consoles are also commonly used in genres and styles of music that benefit from the warmth of analog sound, such as vintage rock, jazz, and classical recordings. They remain popular in high-end professional studios where analog sound character is a priority.

Digital Consoles (Digital Mixers)

Digital consoles, on the other hand, rely on **Digital Signal Processing (DSP)** to manipulate and process audio signals. Instead of using physical components like resistors and capacitors, digital consoles convert audio signals into a digital format, where they can be altered and processed with software algorithms. This shift to digital technology offers more precision, flexibility, and the ability to store complex settings. Digital mixing consoles are highly versatile and compact, offering a significant advantage over traditional analog mixers. By utilizing digital signal processing (DSP) chips, these consoles replace bulky and costly analog equipment, enabling advanced channel equalization, in-line dynamics, effects processing, and output management such as graphic EQs—all within a single system. Digital mixers often boast complex routing options and grouping assignments, making them more flexible than analog counterparts. A key advantage of digital consoles is their ability to copy, store, and recall settings, making them particularly effective for recurring setups with consistent requirements, such as working with the same band. However, this feature also introduces limitations. Adjusting or viewing channel settings is typically restricted to one channel at a time, which can feel cumbersome in dynamic live sound environments. Additionally, while digital mixers provide tools to accelerate workflow, accessing advanced features such as stacked faders or deep control settings may require prior experience. The unique layout of each digital console also presents a learning curve, demanding familiarity to unlock their full potential.

Features:

- **High Flexibility with Programmable Settings:** One of the major advantages of digital consoles is their programmability. Settings such as EQ, effects, dynamics, and routing can be stored as presets, allowing engineers to quickly recall specific configurations without needing to adjust each control manually. This makes digital consoles extremely versatile in dynamic live performance settings where quick changes are often necessary.
- **Integration with DAWs (Digital Audio Workstations):** Digital consoles often integrate seamlessly with digital audio workstations (DAWs), allowing for direct control of software-based audio processing and mixing. This integration enables

smoother workflows and the ability to work with virtual instruments, effects, and automation within a single, unified system.

Applications:

- Digital consoles are commonly used in modern studios and live sound environments due to their adaptability and extensive feature set. They are ideal for large-scale productions, where complex signal routing, multiple input channels, and advanced effects processing are required. Their ability to interface with DAWs makes them especially popular in digital production environments. Additionally, digital mixers are indispensable for live sound performances, where they can manage a large number of audio sources while maintaining flexibility for real-time adjustments. Live concerts, large events, and complex studio setups often rely on digital consoles for their functionality and ease of use.

Comparison of Analog and Digital Consoles

Feature	Analog Consoles	Digital Consoles
Sound Character	Warm, natural, and organic sound	Clean, precise, and flexible sound
Control Interface	Physical knobs, faders, and sliders	Digital interface, often with touchscreens
Signal Processing	Physical circuitry (resistors, capacitors)	Digital signal processing (DSP)
Flexibility	Limited by physical components	Highly flexible, programmable settings
Integration with DAWs	Not integrated	Seamless integration with DAWs
Applications	Traditional studio recordings, analog warmth	Modern studios, live sound, digital production



Analog and Digital Consoles

Both types of consoles have their strengths and limitations, and the choice between analog and digital often depends on the specific needs of the audio production. While analog consoles are revered for their classic sound and tactile control, digital consoles are appreciated for their versatility, precision, and integration with modern audio technologies.

Technical Skills

Operating Audio Mixers and Consoles

Mastering audio mixers and consoles requires a clear understanding of signal flow and proficiency in key operations to ensure high-quality sound output. Below is a detailed breakdown of essential technical skills required for effective operation:

Understanding Signal Flow

The foundation of audio mixing lies in understanding how sound travels through the console:

- **Signal Path:** Input > Gain > Equalization (EQ) > Fader > Output.
- **Routing:** Ensure proper signal routing by assigning each input channel to the correct output, whether it is speakers, headphones, or a recording device. Incorrect routing can lead to loss of sound or unbalanced mixes.
- **Auxiliary Sends:** Use auxiliary (aux) sends to direct specific parts of the audio signal to effects processors or monitor systems without interrupting the main signal flow.

Setting Gain Levels

Proper gain staging is crucial to achieve a clean signal:

- **Input Gain Adjustment:** Start by setting the input gain. Use the console's peak or level meter to ensure signals are neither too low (causing noise) nor too high (causing distortion).
- **Headroom Management:** Leave sufficient headroom to manage unexpected audio peaks without clipping.
- **Pre-fader vs. Post-fader Gain:** Understand the difference; pre-fader affects the input gain independently of the fader position, while post-fader adjusts levels after the fader settings.

Using Equalization (EQ)

Equalization allows you to shape and balance frequencies:

- **Low, Mid, and High Frequencies:** Identify the frequency range of each sound source and use EQ controls to enhance clarity.
 - For vocals, reduce low-end bass to eliminate rumble and emphasize midrange for clarity.

- For instruments like bass guitar, boost low frequencies and attenuate highs to focus the sound.
- **Parametric EQ:** Utilize parametric EQ for precision control over frequency bands when advanced shaping is needed.

Applying Effects

Effects add depth and polish to a mix:

- **Reverb:** Use reverb to simulate the acoustics of a room, enhancing vocal or instrumental performances.
- **Compression:** Apply compression to control dynamic range, making the mix more balanced and cohesive.
- **Delay and Modulation:** Experiment with delay or modulation effects like chorus to create richer soundscapes.
- **Effect Routing:** Ensure effects are applied appropriately by routing through aux sends and returns or dedicated effects channels.

Balancing Audio

Balancing ensures every sound source in the mix contributes harmoniously:

- **Fader Levels:** Adjust channel faders to achieve a blend where no single sound overpowers others unless intended.
- **Panning:** Use the pan control to position sounds in the stereo field, creating a sense of space and dimension. For instance, vocals might stay centred, while guitars pan slightly left or right.
- **Monitor Mixes:** Balance the mix in both main outputs and monitor outputs to suit the audience and performers.

Tips for Optimal Sound Quality

To achieve professional-quality sound, the following tips should be kept in mind:

- **Prevent Clipping:** Avoid overloading inputs by carefully monitoring gain levels and ensuring headroom. Clipping not only distorts sound but can also damage equipment.
- **Monitor Levels:** Regularly check output levels using the console's meters. Meters provide a visual guide to ensure signals remain within safe levels.
- **Use Headphones:** Use high-quality headphones to isolate individual channels for precise adjustments. This is especially helpful in noisy environments or during critical live performances.
- **Room Acoustics:** Consider the acoustic environment and adjust EQ and effects to compensate for reverberation, echoes, or other room-specific challenges.
- **Consistent Monitoring:** Regularly switch between headphones and monitor speakers to ensure the mix translates well to different listening setups.

By mastering these technical skills and applying these tips, operators can achieve a professional and polished audio output in both live as well as studio settings.

Audio Mixers and Audio Consoles: Functions and Features

Audio mixers, also referred to as audio consoles or mixing desks, are the central control units in sound production, designed to manage and manipulate multiple audio signals. Their functionality extends from live performances to studio recordings, making them an essential tool for achieving professional-quality sound. Below is a detailed overview of their key functions and features:

Input Channels

- **Purpose:** Input channels are the starting point where audio signals from microphones, instruments, or playback devices enter the mixer.
- **Features:**
 - **Preamps:** Amplify the signal from low-level sources like microphones to a usable level.
 - **Gain Control:** Adjusts the input signal strength, ensuring proper gain staging to avoid distortion or noise.
 - **EQ Settings:** Channel-specific equalizers allow frequency adjustments to shape the tonal quality of the input.
- **Applications:** These channels can handle anything from vocals and guitars to drums and keyboards, providing flexibility for live or studio setups.

Auxiliary Sends

- **Purpose:** Auxiliary sends, often abbreviated as “aux sends,” are used to route audio signals away from the main mix to external devices or monitors.
- **Features:**
 - **Monitor Mixes:** Send signals to stage monitors or in-ear monitors for live performers to hear themselves.
 - **Effects Processing:** Route signals to external effects processors like reverb or delay units, allowing the processed audio to be blended back into the mix.
 - **Adjustable Levels:** Independent aux send knobs for each channel let users control how much of each signal is sent to the auxiliary output.
- **Applications:** Aux sends are crucial for creating customized monitor mixes or integrating additional effects into the audio setup.

Master Fader

- **Purpose:** The master fader controls the overall output level of the mixer, acting as the final volume adjustment before the audio reaches speakers, recording devices, or amplifiers.
- **Features:**
 - **Stereo Outputs:** Controls the balance and levels of left and right channels for a stereo mix.
 - **Meters:** Visual level indicators help ensure the output does not clip or distort.
 - **Subgroups:** Some consoles allow grouping of channels under a single fader for easier control over sections of a mix, such as drums or vocals.
- **Applications:** In live settings, the master fader ensures that the overall sound output is consistent and clear. In studios, it helps balance the final mix for recording or broadcast.

Advanced Features Found in Modern Mixers

- **Built-in Effects:** Many modern mixers include built-in digital effects like reverb, delay, and compression, reducing the need for external processors.
- **Digital Displays:** Touchscreens or LCD panels provide detailed control and visual feedback for routing and processing.
- **Multitrack Recording:** Some mixers double as audio interfaces, allowing users to record each channel independently to a DAW.
- **Wireless Control:** Advanced mixers support Wi-Fi or Bluetooth connections, enabling remote operation via smartphones or tablets.

By understanding the core functions and features of audio mixers and consoles, users can optimize their use to achieve precise control over sound in any application, from concerts to studio production.

Features and Functions: Comparison

Feature	Analog Consoles	Digital Consoles
Signal Processing	Analog signal chain	Digital signal chain
Control Interface	Physical knobs/sliders	Touchscreen, software
Flexibility	Limited	Highly customizable
Sound Quality	Warm, natural	Precise, clean

More about Digital Mixers

Digital mixers have revolutionized the world of audio production by combining advanced processing power with user-friendly features. They have become an indispensable tool in modern sound engineering due to their versatility, compactness, and adaptability.

Advantages of Digital Mixers

Automation

- **Save and Recall Settings:** Digital mixers allow users to store and recall specific configurations, such as EQ settings, routing, and effects, tailored for different projects or live events.
- **Consistency:** Automation ensures that the same sound quality and mix are reproduced every time, saving time and effort during recurring setups.

Compact Design

- **Space Efficiency:** By replacing bulky analog circuits with digital processors, digital mixers pack more features into smaller footprints, making them easier to transport and set up.
- **All-in-One Capability:** Many digital mixers include built-in effects, multitrack recording, and remote-control options, reducing the need for external gear.

Network Connectivity

- **Integration:** Digital mixers can connect to other devices using LAN, Wi-Fi, or audio networking protocols like Dante and AVB, facilitating seamless communication between equipment.
- **Remote Control:** Wi-Fi-enabled mixers can be operated via tablets or smartphones, allowing sound engineers to adjust settings from anywhere in the venue.

Usage in Professional Settings

Live Sound

- **Quick Setup:** Digital mixers are ideal for live performances due to their ability to save presets and adapt quickly to varying acoustics and stage configurations.
- **Adaptability:** Features like remote control and multi-layer faders allow engineers to manage large input counts efficiently, even in dynamic live environments.

Broadcast

- **Efficient Routing:** Digital mixers enable complex audio routing and multiple outputs for simultaneous broadcasts, recording, and monitoring.
- **Remote Operation:** Networked mixers allow engineers to control audio from distant locations, ensuring smooth operations in live broadcasts or remote productions.

Studio Recording

- **DAW Integration:** Digital mixers seamlessly interface with Digital Audio Workstations (DAWs), allowing users to record, edit, and mix audio with precision.
- **Enhanced Control:** Features like onboard effects, EQ, and dynamics processing reduce the need for additional plugins, streamlining the workflow.

Digital mixers are a powerful addition to any audio setup, whether for live events, recording studios, or broadcasting. Their combination of automation, compactness, and connectivity makes them a preferred choice for professionals seeking efficiency and flexibility.

Learning Activities

Reading

- **Study Manuals and Guides for Different Mixer Models:** Gain a thorough understanding of the features, functions, and specifications of both analog and digital mixers by reviewing product manuals and user guides. This foundational knowledge is essential for operating a variety of mixer types effectively.
- **Articles on Advancements in Digital Mixer Technology:** Explore articles and case studies on the latest advancements in digital mixing technology, including automation, networking capabilities, and built-in DSP features. Understanding current trends will help learners adapt to evolving industry standards.

Practice

- **Hands-On Training with Both Analog and Digital Mixers:** Set up and operate real-world mixers to familiarize yourself with their physical layouts, signal routing, and controls. Focus on tasks such as connecting input devices, setting gain levels, and routing outputs to monitors or recording devices.
- **Experiment with EQ, Effects, and Fader Adjustments:** Practice adjusting equalizers to balance frequencies for clarity, applying effects like reverb and compression to enhance audio quality, and fine-tuning faders to achieve a harmonious mix. This hands-on experience develops practical mixing skills.

Exercise

- **Simulate Mixing Scenarios:**
 1. **Podcast Recording:** Set up and balance multiple vocal tracks with minimal background noise and use EQ to enhance voice clarity.
 2. **Live Band Setup:** Mix multiple inputs, such as vocals, guitars, drums, and keyboards, focusing on achieving a dynamic and balanced sound for a live performance.

- Voice-Over Session:** Record and mix voice-over tracks with background music, ensuring clarity and appropriate audio levels while avoiding clipping or distortion.

By engaging in these activities, learners can build both theoretical knowledge and practical expertise, enabling them to manage audio mixers and consoles confidently in various professional scenarios.

Check your Progress

Short Answer Questions

Question	CO	PO	K
Define audio mixers.	CO3	PO1	K1
What is an audio console?	CO3	PO4	K1
Explain analog mixers.	CO3	PO4	K2
Define digital mixers.	CO3	PO4	K1
Explain the concept of signal flow in audio consoles.	CO3	PO3	K2

Essay Questions

Question	CO	PO	K
Discuss the functions of audio mixers and consoles.	CO3	PO1	K3
Analyze the differences between analog and digital mixers.	CO3	PO4	K4
Explain the signal flow process in audio mixing.	CO3	PO3	K3
Examine the features of modern digital mixers.	CO3	PO4	K4
Evaluate the role of studio equipment in audio production.	CO3	PO5	K5

Unit IV: Digital Audio Technology

(This unit empowers students with foundational knowledge of digital audio technology and hands-on skills in ADC/DAC processes and DAW operations, preparing them for modern audio production environments.)

Fundamentals of Digital Audio Technology

Digital audio technology represents sound as numerical data, enabling precise manipulation, storage, and reproduction. Digital audio technology is a revolutionary approach to sound processing, where audio signals are captured, represented, and stored as numerical data. This digital representation allows for unparalleled precision in the manipulation, storage, and reproduction of sound. Unlike analog formats, which store sound as continuous waveforms, digital audio converts these waveforms into discrete values through a process called sampling, where the amplitude of the sound wave is measured at regular intervals. These numerical values are then encoded into binary format, making them easily storable on digital media and compatible with a wide range of devices and platforms.

The advantages of digital audio technology are numerous. It offers exceptional accuracy in editing, allowing engineers and producers to tweak every nuance of a sound with precision. This precision ensures high fidelity, as digital audio is immune to the noise and degradation commonly associated with analog formats. Furthermore, digital files can be easily duplicated, shared, and distributed without any loss in quality, making them ideal for modern multimedia applications.

Storage is another area where digital audio excels. Enormous amounts of high-quality audio can be compressed into portable file formats like MP3 or WAV, ensuring easy management and accessibility. Additionally, digital audio is instrumental in enabling advanced features such as real-time effects, automation, and integration with digital audio workstations (DAWs). These capabilities empower creators to push the boundaries of sound design, production, and reproduction.

Digital audio technology has transformed the way sound is recorded, edited, and enjoyed, setting the stage for innovative applications in entertainment, communication, and beyond.

Key Concepts in Digital Audio Technology

Sampling

Sampling is the fundamental process through which analog audio signals are converted into digital data. It involves measuring the amplitude (or intensity) of an audio waveform

at consistent and precisely timed intervals. These measurements are then stored as numerical values to recreate the original sound digitally.

- **Sampling Rate:** This refers to the number of times the audio signal is sampled per second and is measured in Hertz (Hz). A higher sampling rate results in a more accurate representation of the original sound. Commonly used sampling rates include:
 - **44.1 kHz:** Standard for CDs, providing a frequency range sufficient to cover human hearing (20 Hz-20 kHz).
 - **48 kHz:** Commonly used in professional audio and video production for better fidelity and synchronization with video standards.
 - **Higher Rates** (e.g., 96 kHz, 192 kHz): Used in specialized applications like high-resolution audio or archival recordings, offering even greater detail.

The sampling rate determines the maximum frequency that can be faithfully reproduced, known as the Nyquist frequency, which is half the sampling rate.

Bit Depth

Bit depth defines the number of bits used to store each sample of an audio signal, directly affecting the audio's dynamic range and quality.

Dynamic Range: The difference between the softest and loudest parts of an audio signal that can be captured without distortion. A higher bit depth enables greater dynamic range, resulting in clearer and more nuanced audio.

Common Bit Depths:

- **16-bit:** Standard for CDs, offering a dynamic range of 96 dB.
- **24-bit:** Professional-grade audio with a dynamic range of 144 dB, ideal for capturing subtle details and reducing quantization noise.

Higher bit depths not only improve audio fidelity but also reduce the likelihood of unwanted artifacts, such as background hiss or distortion, especially during complex editing and mixing processes.

Together, **sampling rate** and **bit depth** form the foundation of digital audio quality, influencing how accurately and dynamically sound is reproduced and experienced.

Digital Audio Formats:

Digital audio formats determine how sound is encoded, stored, and played back. They are broadly categorized into **lossless** and **lossy** formats, each serving different purposes based on the balance between audio quality and file size.

Lossless Formats

Lossless audio formats preserve the original quality of the audio signal without any loss of data, ensuring high fidelity. These formats are ideal for professional use, archival purposes, and audiophiles seeking uncompromised sound quality.

- **WAV (Waveform Audio File Format):**
 - Developed by Microsoft and IBM, WAV is a standard for uncompressed audio storage.
 - It offers excellent quality, making it suitable for professional recording and editing.
 - Drawback: Large file sizes due to its uncompressed nature.
- **FLAC (Free Lossless Audio Codec):**
 - A compressed lossless format that reduces file size without affecting audio quality.
 - Popular among music enthusiasts for archiving high-quality audio.
 - Advantage: Smaller file size compared to WAV, while maintaining the same audio fidelity.

Lossy Formats

Lossy audio formats achieve significant file size reduction by compressing audio and discarding parts of the data deemed less audible to human ears. While this results in some quality loss, these formats are widely used for streaming and consumer-level playback due to their convenience.

- **MP3 (MPEG Audio Layer III):**
 - The most popular lossy format, known for its universal compatibility.
 - Compression significantly reduces file size, making it suitable for portable devices and streaming.
 - Drawback: Noticeable loss of quality at lower bitrates.
- **AAC (Advanced Audio Codec):**
 - Offers better sound quality than MP3 at similar bitrates.
 - Widely used in platforms like Apple Music and YouTube.
 - Supports additional features like multi-channel audio, making it versatile for modern applications.

Choosing the Right Format

- **For Professional Use:** Lossless formats like WAV or FLAC are recommended for their high-quality preservation, especially during recording, mixing, or mastering.
- **For Everyday Use:** Lossy formats like MP3 and AAC are ideal for personal listening, where file size and compatibility are prioritized over pristine quality.

By understanding the strengths and limitations of these formats, users can select the most suitable option for their specific audio requirements.

Sampling: Diagram

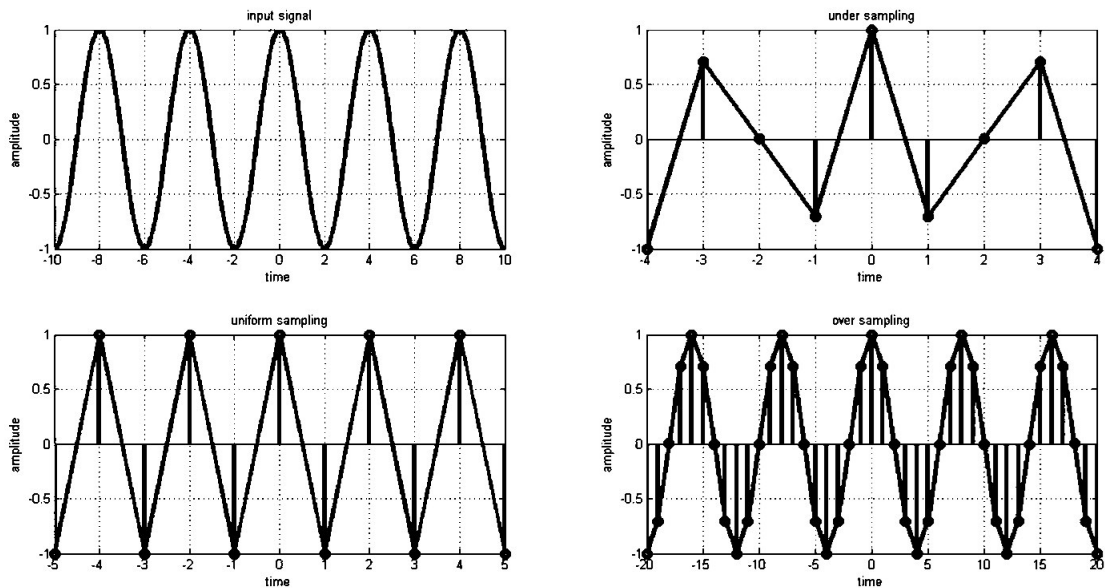

Sine wave from analog; to digital - under sampling, uniform sampling and over sampling.

ADC and DAC

Analog-to-Digital Conversion (ADC)

Analog-to-digital conversion is a crucial process in audio production that enables the transformation of continuous analog signals, such as sound waves, into discrete digital data that can be processed, stored, and manipulated by computers and digital systems. The ADC process involves several stages:

Sampling:

The first step in ADC is sampling, where the continuous analog signal is measured at regular intervals. The frequency at which these samples are taken is called the **sampling rate**, typically measured in Hertz (Hz). For example, a 44.1 kHz sampling rate captures 44,100 samples per second, as used in CD-quality audio.

Quantization:

Once the signal is sampled, each sample is assigned a value based on its amplitude. These amplitude values are quantized, meaning they are mapped to a finite set of levels. The more levels available for quantization (determined by **bit depth**), the more accurately the digital representation mirrors the original analog signal. Higher bit depths, like 24-bit, offer greater precision and dynamic range compared to 16-bit depth (standard CD audio).

Encoding:

The last step in ADC is encoding, where the quantized values are converted into binary data. This data can then be processed, transmitted, or stored for later use, such as editing

or mixing. The binary format is essential for all digital audio devices, ensuring compatibility and consistency across systems.

Digital-to-Analog Conversion (DAC)

Digital-to-analog conversion is the reverse process, where digital audio data is transformed back into analog signals that can be played through speakers or headphones. The DAC process is crucial for accurate audio playback in any system that relies on digital audio files. The steps involved are:

Decoding:

The first step in DAC is decoding, where the binary data (such as from a digital audio file) is converted back into its corresponding quantized values. These values are typically represented as discrete steps along a waveform, mimicking the amplitude of the original analog signal.

Smoothing:

The discrete steps from the decoded signal are still not a perfect analog waveform. To reconstruct a smooth, continuous signal, DAC systems use **smoothing** filters (often low-pass filters) to eliminate digital artifacts and create a smooth wave. This process helps reduce unwanted noise or harshness that might arise from the sampling process.

Applications in Audio Production

ADC in Audio Production: ADCs are essential in the initial stages of digital audio production. For example, when a microphone captures sound from a live performance, the analog audio signal is converted into a digital signal via an ADC, allowing for subsequent editing, mixing, and mastering in a digital audio workstation (DAW).

DAC in Audio Playback: DACs are used in playback systems to convert the stored digital audio data back into analog signals. Audio interfaces, headphones, or studio monitors all rely on DACs to accurately reproduce the sound. High-quality DACs are especially important in professional settings, where fidelity and accuracy are paramount.

- **ADC Example:**

A **microphone** with a built-in ADC converts sound (analog signal) into a digital signal. This is crucial for digital recording systems, where the microphone's output must be converted into digital form for further processing and storage.

- **DAC Example:**

An **audio interface** or digital-to-analog converter (DAC) is responsible for converting digital audio data from a computer or other source into an analog signal that can be played through **studio monitors** or **headphones**, ensuring accurate sound reproduction for mixing or listening.

By understanding ADC and DAC processes, audio professionals can ensure high-quality digital audio capture and playback, essential for both recording and live sound environments.

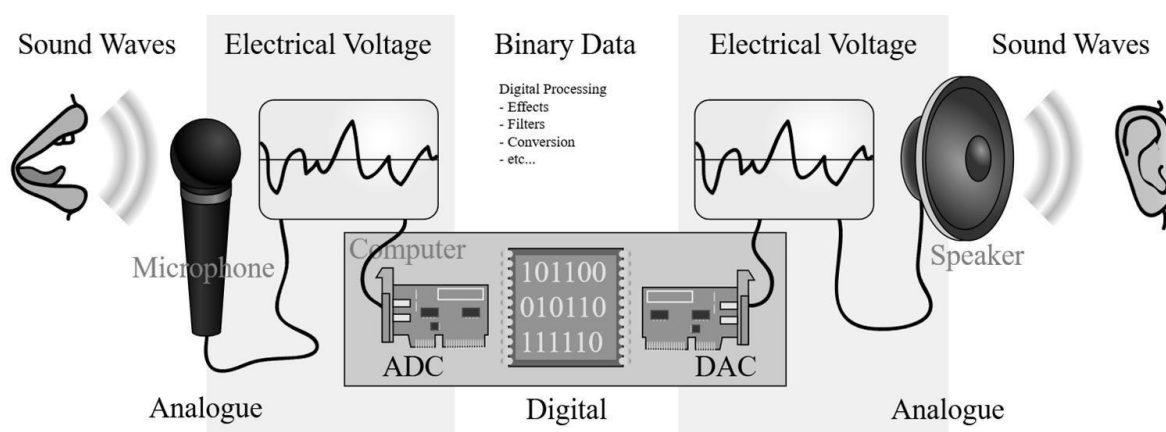

ADC C DAC: Diagram

Digital Audio Workstation (DAW)

A **Digital Audio Workstation (DAW)** is a software platform that allows for the recording, editing, mixing, and production of audio. DAWs have become essential tools for musicians, sound engineers, podcasters, and producers across various audio production environments. They provide an all-in-one solution for working with digital audio, offering a range of features from simple editing tasks to complex sound design and music production.

Popular DAWs:

Pro Tools:

Often regarded as the industry standard, **Pro Tools** is a versatile DAW used extensively in music production, film scoring, and post-production. It offers a powerful suite of features for recording, editing, mixing, and mastering, making it ideal for professional studios. With its robust toolset and seamless integration with hardware, Pro Tools excels in handling large, complex sessions.

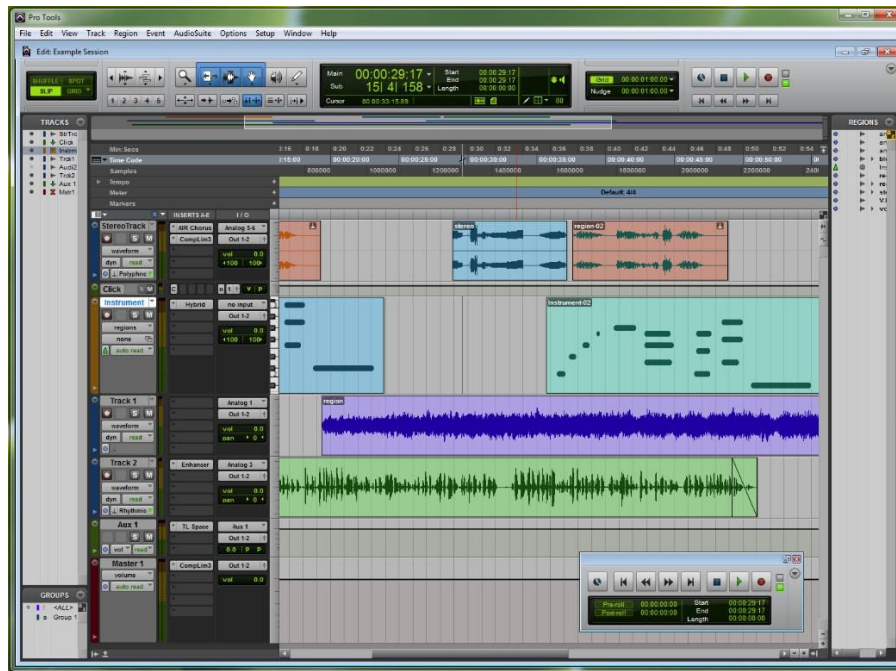

Pro Tools – Interface

Features: Advanced editing tools, multi-track recording, high-quality audio processing, professional mixing capabilities, and extensive plugin support.

Ableton Live:

Ableton Live is known for its real-time audio manipulation and is particularly popular among electronic music producers, DJs, and live performers. Its unique session view allows users to experiment with loops and samples, making it a favorite for non-linear composition and live performances. Ableton Live's versatility extends to traditional studio recording and mixing, making it suitable for a wide range of musical genres.



Ableton Live – Interface

Features: Real-time audio manipulation, session view for live performances, powerful MIDI capabilities, comprehensive suite of virtual instruments and effects.

Audacity:

Audacity is a free, open-source DAW that provides a basic yet effective platform for audio recording and editing. It is ideal for beginners, podcasters, and those working on smaller-scale audio projects. While it lacks the advanced features of other DAWs, Audacity is simple to use and supports multi-track recording, basic effects, and audio manipulation.

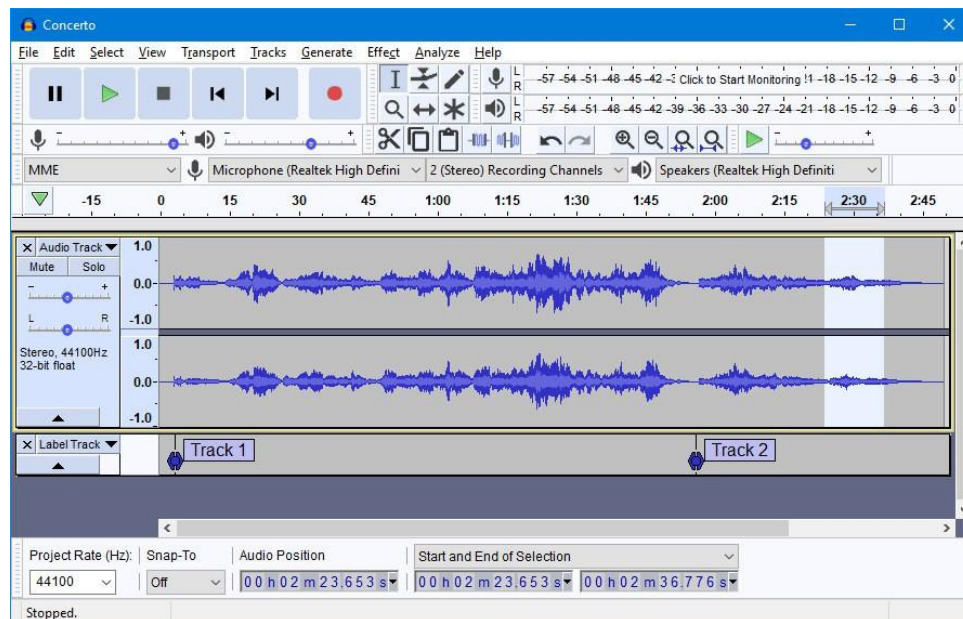

Audacity - Interface

Features: Multi-track recording, basic editing tools, a wide range of free plugins, and support for various audio file formats.

FL Studio:

FL Studio, formerly known as Fruity Loops, is a highly popular DAW, particularly in the world of electronic music and hip-hop production. Known for its user-friendly interface, FL Studio offers powerful tools for beat-making, arranging, and mixing. It is preferred for its intuitive pattern-based workflow, making it easy to create loops, drum patterns, and melodies.

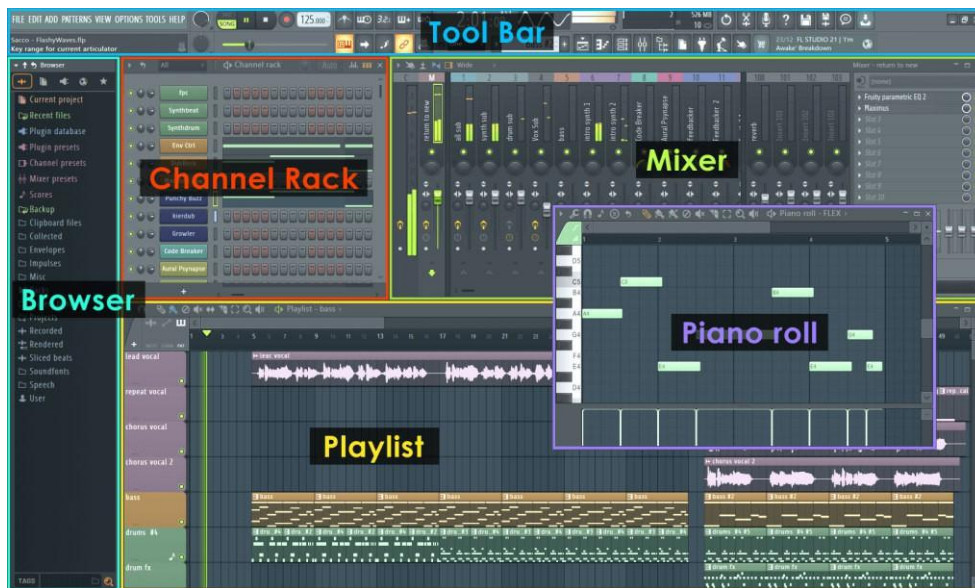

FI Studio - Interface

Features: Piano roll for advanced MIDI editing, pattern-based workflow, a wide range of virtual instruments and effects, real-time audio manipulation, and a robust step sequencer for rhythm programming. It is also known for its flexibility in arranging compositions and its support for third-party plugins.

These DAWs, each with its unique strengths, cater to a broad spectrum of audio production needs, from professional studio environments to live performances and home recording setups. Whether you are working with complex multitrack projects, experimenting with electronic music, or simply recording voiceovers, the right DAW can streamline your workflow and enhance your creative output.

Using a DAW: Step-by-Step Guide

Setup:

Connect Audio Interfaces: The first step is connecting any audio input and output devices, such as microphones, instruments, or audio interfaces, to your DAW. Make sure that your DAW recognizes your interface and configure the necessary settings (input/output channels, buffer size).

Configure Sample Rate and Bit Depth: In your DAW's settings, choose an appropriate sample rate (e.g., 44.1 kHz, 48 kHz) and bit depth (e.g., 16-bit, 24-bit). The sample rate defines how many samples per second are taken from the audio signal, while the bit depth determines the dynamic range and resolution of the audio.

Recording:

Create a New Track: Open a new project in your DAW and add a track for recording. Ensure that the correct input channel (e.g., microphone or instrument input) is selected for the track.

Arm the Track for Recording: Enable the record button on the track to “arm” it. This prepares the track to record audio.

Press Record: Once the track is armed, press the record button on the DAW's transport bar to start capturing audio. When finished, stop the recording to save the audio clip.

Editing:

Trim, Split, and Arrange Clips: After recording, use editing tools in the DAW to trim unnecessary parts of the audio, split clips into separate sections, and rearrange them in the timeline.

Crossfades and Transitions: For seamless transitions between clips, use crossfades or fade-in/fade-out effects to smooth over abrupt starts or stops in the audio.

Mixing:

Volume and Panning: Adjust the volume levels of each track to achieve the desired balance in the mix. Use the pan control to position tracks in the stereo field, creating a sense of space and depth.

Equalization (EQ): Apply EQ to adjust the frequency balance of each track, ensuring that each element in the mix occupies its own frequency range and avoids clashes (e.g., reduce low-end frequencies on vocals to clear up space for bass).

Apply Effects: Use built-in or third-party plugins to apply effects such as **reverb** for spatial depth, **compression** to control dynamics, or **delay** to add rhythmic effects.

Exporting:

Render the Final Mix: Once the mix is complete, export the project as a final audio file. Choose the desired format (e.g., WAV for high-quality audio or MP3 for compressed files) and select the appropriate bit rate or sample rate for your target platform or use.

Export Settings: You can also choose to export a portion of the project, such as a single track or a specific time range and save it in different file formats depending on the needs (e.g., for streaming platforms, CD, or broadcast).

By mastering the DAW setup, recording, editing, mixing, and exporting processes, audio producers can create polished, professional-quality audio projects suitable for various applications, including music production, podcasts, sound design, and more. Each DAW has its own strengths and unique features, but the core principles remain the same across all platforms.

Learning Activities

Reading:

Study tutorials on sampling, bit depth, and file formats: Familiarize yourself with the fundamental concepts of digital audio, including the importance of sampling rates and bit depths in maintaining audio quality. Understanding how these factors affect the fidelity of recordings will help you make informed decisions during production.

Review DAW manuals for specific features and workflows: Delve into the manuals of various Digital Audio Workstations (DAWs), such as Pro Tools, FL Studio, or Audacity, to explore specific tools and functionalities. Each DAW has a unique workflow, and understanding how to efficiently navigate through them can significantly enhance your productivity and creativity during audio production.

Practice:

Use free DAWs like Audacity to record and edit a voice-over: Practice recording and editing basic audio projects, such as voice-overs, using free DAWs like Audacity. Focus on techniques like trimming, fading, and cleaning up recordings to ensure clarity and smoothness in the final product.

Experiment with applying EQ and reverb to enhance recordings: Enhance your audio editing skills by experimenting with equalization (EQ) to adjust frequency ranges and applying reverb to simulate different acoustic environments. This practice will help you understand how these effects can shape the sound of a recording.

Exercise:

Convert analog audio (e.g., cassette recordings) to digital format using an audio interface: Convert analog audio recordings, such as those from cassettes or vinyl records to digital formats by connecting a cassette player or turntable to an audio interface. This exercise will provide hands-on experience with analog-to-digital conversion and understanding the nuances of digitizing vintage media.

Export a digital audio project back to an analog medium (e.g., record it onto a tape): Practice the process of taking a digital audio file and converting it back to an analog format by recording it onto a cassette or tape deck. This exercise will allow you to experience both ends of the audio format spectrum, deepening your understanding of digital-analog conversion and the unique characteristics of each medium.

Check Your Progress

Short Answer Questions

Question	CO	PO	K
Define digital audio technology.	CO4	PO1	K1
What is sampling in digital audio?	CO4	PO4	K1
Explain analog-to-digital conversion (ADC).	CO4	PO4	K2
Define digital-to-analog conversion (DAC).	CO4	PO4	K1
What is a Digital Audio Workstation (DAW)?	CO4	PO4	K2

Essay Questions

Question	CO	PO	K
Discuss the fundamentals of digital audio technology.	C04	PO1	K3
Analyze the process of sampling in digital audio systems.	C04	PO4	K4
Explain the role of ADC and DAC in audio production.	C04	PO4	K3
Examine the functions of Digital Audio Workstations in modern media production.	C04	PO4	K4
Evaluate the impact of digital technology on audio production.	C04	PO5	K5

Unit V: Mixing and Mastering Techniques

(This unit offers a comprehensive understanding of mixing and mastering techniques, enabling students to produce professional-grade audio using modern tools and technologies.)

Combining Individual Tracks

Mixing is the art of combining multiple audio tracks into a cohesive and polished final output. It involves balancing, processing, and blending individual elements to ensure clarity, depth, and an engaging listening experience. Effective mixing is both technical and creative, requiring attention to the detail and a good ear.

Techniques for Balancing and Blending Tracks

Volume Balancing:

- **Definition:** Adjusting the levels of individual tracks to ensure that all elements are audible and work harmoniously within the mix.
- **Key Practice:** Use **gain staging** to optimize signal levels and avoid distortion or clipping during processing.
- **Example:** Ensure vocals remain prominent without overpowering the instrumental tracks.

Panning:

- **Definition:** Distributing audio signals across the stereo field to create depth and width in the mix.
- **Key Practice:** Position core elements like vocals and bass at the center for focus, while spreading other elements like guitars or percussion across the stereo spectrum for spatial effect.
- **Example:** Place a rhythm guitar slightly to the left and a lead guitar slightly to the right to create a balanced stereo image.

Equalization (EQ):

- **Definition:** Cutting or boosting specific frequency ranges to prevent sonic clashes and enhance clarity.
- **Key Practice:** Identify and address overlapping frequencies between instruments to ensure each element has its own space.
- **Example:** Reduce the low frequencies in a guitar track to make room for the punch of the kick drum.

Dynamic Processing:

1. **Compressors:**

- Use compressors to tame sudden volume changes, ensuring a smooth and consistent sound.

- Example: Control the dynamic range of a vocal track so soft parts remain audible and loud parts are not overpowering.
2. **Limiters:**
 - Apply limiters to manage extreme peaks and protect the mix from distortion during playback.
 - Example: Prevent transient spikes from a snare drum that could clip the master output.

Reverb and Delay:

1. **Reverb:**
 - Add reverb to simulate natural spaces and add dimension to the mix.
 - Example: Apply subtle reverb to vocals to create a sense of depth without overwhelming the clarity.
2. **Delay:**
 - Use delay effects to create rhythmic echoes or broaden the sound.
 - Example: Add a timed delay to a lead guitar to fill out the soundstage without cluttering the mix.

Mixing is a balance of science and artistry, where technical precision meets creative intuition. By applying these techniques, audio engineers can sculpt professional-quality mixes that captivate and immerse the listener.

Recording and Editing Skills

Step-by-Step Guide on Recording and Editing Audio

Preparation

1. **Setup Microphones and Instruments:**
 - Place microphones appropriately to capture the desired sound source with clarity.
 - Ensure instruments are tuned, and all connections (cables, interfaces) are secure.
2. **Configure Recording Software:**
 - Set up your DAW (Digital Audio Workstation) with the correct sample rate and bit depth.
 - Create and label tracks for easier management during recording and editing.
3. **Check Recording Levels:**

- Test input levels to ensure they are neither too low (causing noise) nor too high (resulting in distortion).
- Aim for levels peaking between -12 dB and -6 dB for optimal headroom.

Recording Process

- 1. Segmented Recording:**
 - Record in smaller sections or takes to focus on precision and reduce mistakes.
 - Example: Break down a song into verses, chorus, and bridge for focused recording.
- 2. Use a Metronome or Click Track:**
 - Maintain consistent tempo during recording sessions, especially for music.
 - Helps align tracks during multi-instrument or vocal layering.
- 3. Monitor While Recording:**
 - Use headphones to monitor sound in real time, ensuring accurate performance and levels.

Editing Techniques

- 1. Trimming:**
 - Remove unwanted sections such as silences, false starts, or errors.
 - Example: Cut the first few seconds of ambient noise before a performance begins.
- 2. Crossfading:**
 - Apply smooth transitions between clips to avoid abrupt audio changes.
 - Ideal for joining multiple takes seamlessly.
- 3. Noise Reduction:**
 - Use DAW tools or plugins to eliminate background hum, hiss, or static.
 - Be cautious to avoid affecting the natural sound quality of the recording.
- 4. Time Alignment:**
 - Adjust timing inconsistencies between tracks to ensure synchronization.
 - Useful for vocal harmonies or multi-instrument recordings.

Tips for Professional-Quality Recordings

- **Acoustically Treated Space:**
 - Record in a room with acoustic panels or blankets to reduce echoes and reverberation.
 - Example: Avoid recording in rooms with hard, reflective surfaces like tiles or glass.
- **Use High-Quality Equipment:**

- Invest in reliable microphones and audio interfaces for clean and accurate sound capture.
- Example: A condenser microphone for vocals or an audio interface with preamps for instruments.
- **Perform Multiple Takes:**
 - Record several takes to capture the best performance and have options during editing.
 - Example: Vocalists can experiment with different expressions or emphasis on specific lyrics.

By combining careful preparation, efficient recording practices, and meticulous editing, you can achieve polished audio recordings suitable for professional use.

Audio Recording Software

Overview of Popular Recording Software

1. **Pro Tools:**
 - Industry-standard DAW for professional studios.
 - Features advanced editing tools, MIDI integration, and extensive plugin support.
2. **Logic Pro:**
 - Apple-exclusive DAW known for its user-friendly interface.
 - Ideal for music composition and mixing.
3. **Audacity:**
 - Free, open-source DAW for beginners.
 - Features basic editing tools and multi-track recording.

Comparison Chart

Software	Platform	Features	Best For
Pro Tools	Windows, Mac	Advanced mixing and mastering	Professional studios
Logic Pro	Mac	User-friendly, built-in instruments	Composers and producers
Audacity	Windows, Mac, Linux	Free, lightweight	Beginners and hobbyists

Audio Recording and Editing Software - General Workflow

Recording

- 1. Create a New Project:**
 - Open your Digital Audio Workstation (DAW) and start a new project.
 - Set the project sample rate (e.g., 44.1 kHz or 48 kHz) and bit depth (e.g., 24-bit) for optimal recording quality.
- 2. Configure Input Devices:**
 - Connect your audio interface to the computer and ensure it is recognized by the DAW.
 - Assign inputs (e.g., microphones or instruments) to corresponding tracks in the DAW.
- 3. Arm Tracks for Recording:**
 - Select the track you want to record on and "arm" it by clicking the record-enable button.
 - Monitor levels to ensure audio signals are within the ideal range (-12 dB to -6 dB).
- 4. Start Capturing Audio:**
 - Click the record button in the DAW to begin recording.
 - Perform your piece, ensuring consistent sound quality throughout the session.

Editing

- 1. Split and Trim Tracks:**
 - Use tools like the **scissors tool** to divide tracks into sections.
 - Delete unwanted portions such as false starts, background noise, or errors.
- 2. Arrange Audio Clips:**
 - Drag and arrange audio clips on the timeline to match your desired sequence.
 - Use snapping features to align clips with the tempo grid if working on music.
- 3. Apply Automation:**
 - Use automation lanes to adjust parameters like volume, pan, or effects dynamically over time.
 - Example: Gradually increase volume during a buildup or fade out a track at the end.

4. Apply Noise Reduction:

- Use plugins or native tools to remove background noise, pops, or hums without degrading the audio quality.

Mixing and Mastering

1. Integrate Plugins:

- Insert **EQ plugins** to balance frequencies, **compression** to control dynamics, and **reverb** to add spatial effects.
- Example: Use a parametric EQ to cut low-mid frequencies in vocals for clarity.

2. Balance Tracks:

- Adjust individual track faders for consistent levels across the mix.
- Use pan controls to distribute sounds across the stereo field (e.g., instruments on the left, vocals at the centre).

3. Mastering:

- Apply a limiter to ensure the final mix does not exceed 0 dB, preventing clipping.
- Use metering tools to check loudness levels and ensure the mix adheres to industry standards (e.g., -14 LUFS for streaming platforms).

4. Export Final Mix:

- Render the project into your desired format, such as WAV for high-quality audio or MP3 for compressed files.
- Configure settings like bitrate and sample rate during export to meet project requirements.

These are the steps involved in using software tools to create a professional-grade audio project, from initial recording to the final mastered mix.

Check Your Progress

Short Answer Questions

Question	CO	PO	K
Define audio mixing.	CO5	PO1	K1
What is audio mastering?	CO5	PO4	K1
Explain track balancing in audio mixing.	CO5	PO4	K2
Define audio editing.	CO5	PO4	K1
Explain the role of recording software in audio production.	CO5	PO4	K2

Essay Questions

Question	CO	PO	K
Discuss the process of audio mixing in production.	C05	PO4	K3
Analyze the techniques used in mastering audio tracks.	C05	PO4	K4
Explain the workflow of recording and editing audio.	C05	PO4	K3
Examine the importance of audio recording software in production.	C05	PO4	K4
Evaluate the significance of mixing and mastering in professional audio production.	C05	PO5	K5